

Product Description

MECKu15SCFE is a 0.15 μm GaN based MMIC integrating the main functions of a T/R Module Frontend (HPA, TR Switch and LNA) for Ku-band Radar applications in the frequency range 13 – 16 GHz.

Optimized to be compliant with space de-rating standard, the transmitting path can deliver a saturated power of about 9 W with a PAE of 34% and 25 dB of large signal Gain. The receive chain offers 24 dB Gain with Noise Figure of 2.5 dB and saturated output power internally limited to 15 dBm. The SCFE (Single-Chip Front-End), satisfy the reliability constraints with input power at the Antenna port up to 20 dBm, during nominal operating conditions, and up to 27 dBm in Off mode (DC floating).

The Tx/Rx switching time is faster than 50 ns, while the Recovery time of the receive path is lower than 10 ns after a jamming signal of 20 dBm.

Two control voltages (one plus its inverted) required for Tx/Rx switching.

The SCFE is designed to be tolerant to power reflection up to VSWR of 3:1 of mismatch at the antenna port.

Applications

- SAR
- Commercial and Military Radar

Main Features

- 0.15 μm GaN/SiC space evaluated process
- Frequency range: 13 – 16 GHz
- Chip Size: 6.0 x 3.4 x 0.07 mm³
- Switching Time: 50 ns

Tx chain (pulsed)

- Small Signal Gain: 35 dB
- Large Signal Gain: 25 dB
- Output Power @ PAEmax: 38.5 dBm
- PAE: 34%
- Harmonic Suppression: 45 dBc
- Tolerance to Load-pulling: 3:1 VSWR
- Bias: $V_d = 17.5 \text{ V}$, $I_{dq} = 400 \text{ mA}$

Rx chain (CW)

- Small Signal Gain: 24 dB
- Noise Figure: 2.5 dB
- Saturated Power: 15 dBm
- Output TOI: 16 dBm
- Input P1dB: -10 dBm
- Phase Stability: 2.5 $^\circ\text{pp}$ / 250 MHz
- Recovery Time: 10 ns
- Bias: $V_d = 10 \text{ V}$, $I_{dq} = 35 \text{ mA}$

Functional Block Diagram

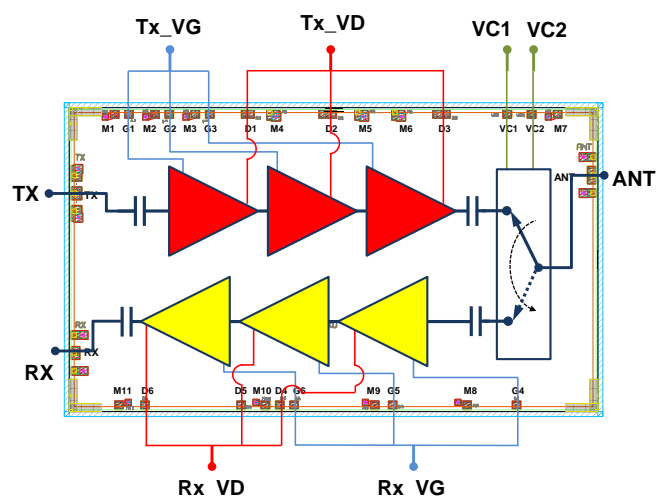

Nominal Operating Conditions

Parameter	Value	Description
Tamb	-30 to +90 °C	Operating temperature range
Transmit Mode		
VC1	-20 V	TX/RX control voltage
VC2	0 V	TX/RX control voltage
IC1, IC2	0 A	Current drained by control voltage VC1 and VC2
Gate Pulse Length	up to 100 µsec	
Gate Pulse Duty Cycle	up to 40%	
Tx_VG	-2.8 V (Typ.)	TX Gate Voltage – to be pulsed in the range [-5 to -2.8] V
Tx_VD	17.5 V	TX Drain Voltage
Tx_IDq	0.4 A	TX Drain quiescent Current
Tx_IG	0 mA	TX Gate Current
Rx_VG	-7 V	RX Gate Voltage
Rx_VD	10 V	RX Drain Voltage
Rx_IDq	0 A	RX Drain quiescent Current
Receive Mode		
VC1	-0 V	TX/RX control voltage
VC2	-20 V	TX/RX control voltage
IC	0 A	Current drained by control voltage VC
Tx_VG	-5 V (Typ.)	TX Gate Voltage – to be pulsed in the range [-5 to -2.8] V
Tx_VD	17.5 V	TX Drain Voltage
Tx_IDq	0 A	TX Drain quiescent Current
Rx_VG	-2.6 V	RX Gate Voltage
Rx_VD	10 V	RX Drain Voltage
Rx_IDq	35 mA	RX Drain quiescent Current
Rx_IG	0 mA	RX Gate Current

Absolute Maximum Rating

Parameter	Description	Value
Tx_VD, Rx_VD	Drain Voltage	27 V
Tx_IDq	TX Quiescent Drain Bias Current (pulsed)	0.8 A
Rx_IDq	RX Quiescent Drain Bias Current	60 mA
Tx_VG, Rx_VG	TX Gate Voltage	-7 to -1 V
Tx_IG	TX Gate Current	112 mA
Rx_IG	RX Gate Current	24 mA
VC	TX/RX control voltage	-50 V
IC	TX/RX control voltage	24 mA
Pin_Tx	Input power at TX port	24 dBm
Pin_Rx	Input power at ANTENNA port	20 dBm
Tch	Channel temperature	230 °C
Tmnt	Mounting Temperature (<30 sec)	260 °C
Tstg	Storage Temperature range	-55 to +150 °C

Operation of this device above any one of these parameters may cause permanent damage.

Electrical Characteristics – Transmit

Test conditions unless otherwise noted: $Tx_VD = 17.5\text{ V}$, $Tx_IDq = 0.4\text{ A}$, $VC1 = -20\text{ V}$, $VC2 = 0\text{ V}$, $Tx_VG\ pulse = (150\ \mu s - 30\%)$, $Rx_VD = 10\text{ V}$, $Rx_VG = -7\text{ V}$. $Tbase = 30^\circ\text{C}$.

Parameter	Min	Typ	Max	Unit
Operating frequency	13		16	GHz
Small Signal Gain		35		dB
Input Return Loss	18			dB
Output Return Loss	18			dB
Output Power at PAE max. (Pin=14.5 dBm)		39.5		dBm
Output Power at Saturation (Pin = 17 dBm)		40		dBm
PAE max. (Pin=14.5 dBm)		35		%
Harmonic Suppression	48		65	dBc
Isolation TX-RX	30			dB
Power Leakage at RX port			-20	dBm
Supply Drain Current at PAE max. (Pin=14.5 dBm)		1.5		A
Supply Drain Current at Saturation (Pin = 19 dBm)		1.6		A
Gate Leakage Current		0		mA
Switching Setting Time ⁽¹⁾ , Rising & Falling			30	ns

(1) From 50% trigger signal to 90% of RF on (Rising) or 10% of RF off (Falling).

Electrical Characteristics – Receive

Test conditions unless otherwise noted: $Rx_VD = 10\text{ V}$, $Rx_IDq = 35\text{ mA}$, $VC1 = 0\text{ V}$, $VC2 = -20\text{ V}$, $Tx_VD = 17.5\text{ V}$, $Tx_VG = -5\text{ V}$. $Tbase = 30^\circ\text{C}$.

Parameter	Min	Typ	Max	Unit
Operating frequency	13		16	GHz
Small Signal Gain, over frequency		24.5		dB
Small Signal Gain @ +15 °C to 90 °C	22.5		25	dB
Gain Temperature Coefficient		-0.03		dB/°C
Noise Figure		2.5		dB
Input Return Loss	17			dB
Output Return Loss	16			dB
Saturated Output Power		15		dBm
Output TOI @ -33 dBm Pin / Tone		16		dBm
Recovery Time			10	ns
Gate Leakage Current		0		mA
Switching Setting Time(1), Rising & Falling			30	ns

(1) From 50% trigger signal to 90% of RF on (Rising) or 10% of RF off (Falling).

Small Signal Performance – Transmit

Test conditions unless otherwise noted: $Tx_VD = 17.5\text{ V}$, $Tx_IDq = 0.4\text{ A}$, $VC1 = -20\text{ V}$, $VC2 = 0\text{ V}$, TX_VG pulse = (150 μs – 30%), $Rx_VD = 10\text{ V}$, $Rx_VG = -7\text{ V}$.

Linear Gain Vs. Temperature

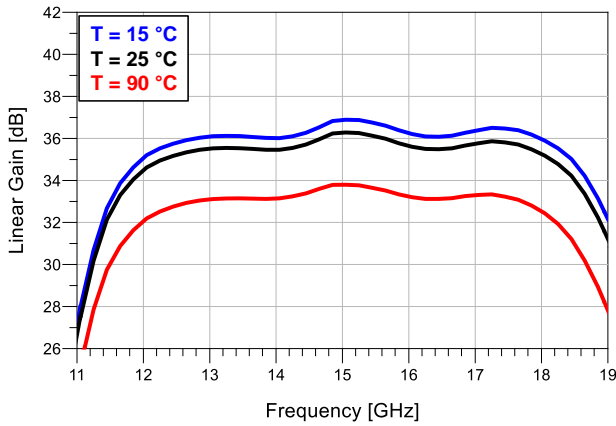

Reverse Isolation Vs. Temperature

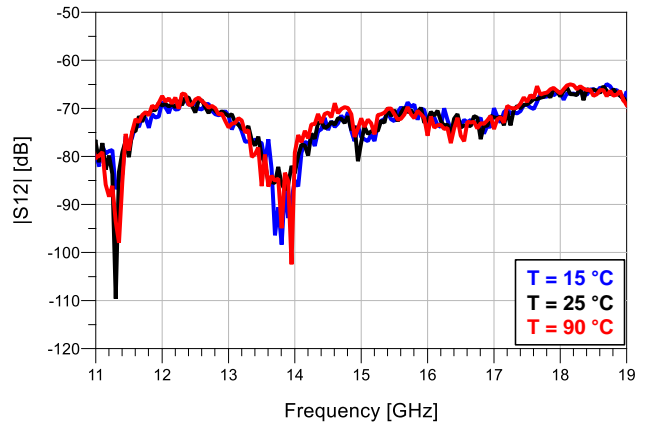

Input Return Loss Vs. Temperature

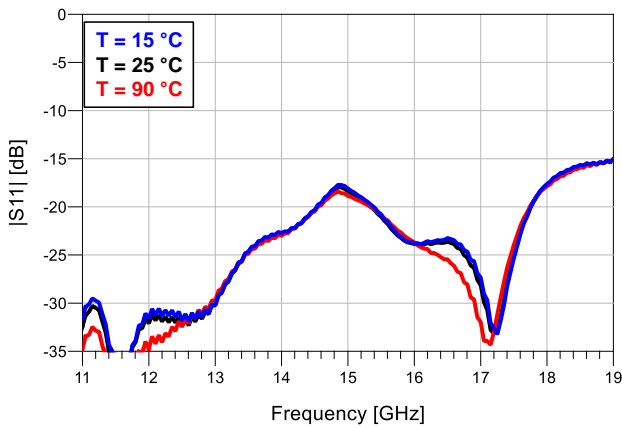

Output Return Loss Vs. Temperature

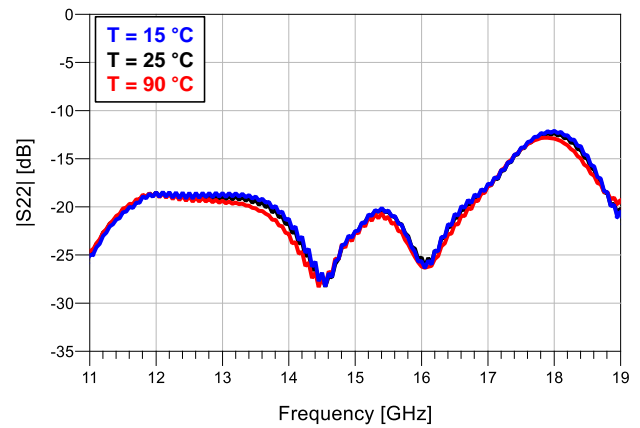

Power Performance – Transmit

Test conditions unless otherwise noted: $Tx_VD = 17.5\text{ V}$, $Tx_IDq = 0.4\text{ A}$, $VC1 = -20\text{ V}$, $VC2 = 0\text{ V}$, TX_VG pulse = (150 μs – 30%), $Rx_VD = 10\text{ V}$, $Rx_VG = -7\text{ V}$. $Pin = 14.5\text{ dBm}$ (@ 25 °C) and 16.5 dBm (@ 90 °C)

Power Vs. Temperature

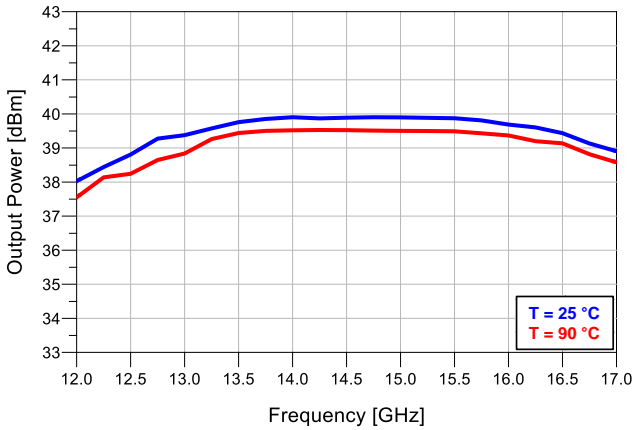

PAE Vs. Temperature

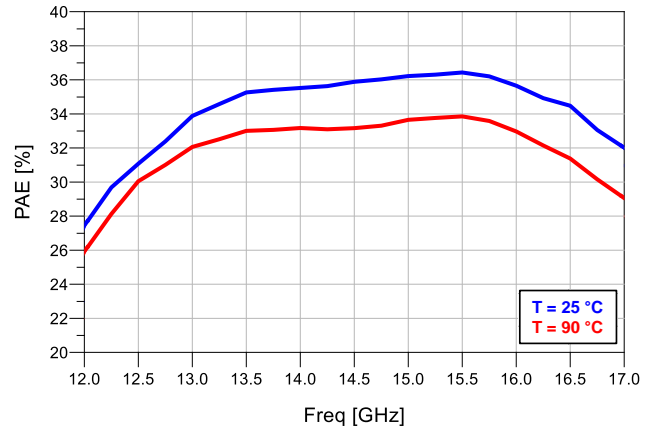

Power Gain Vs. Temperature

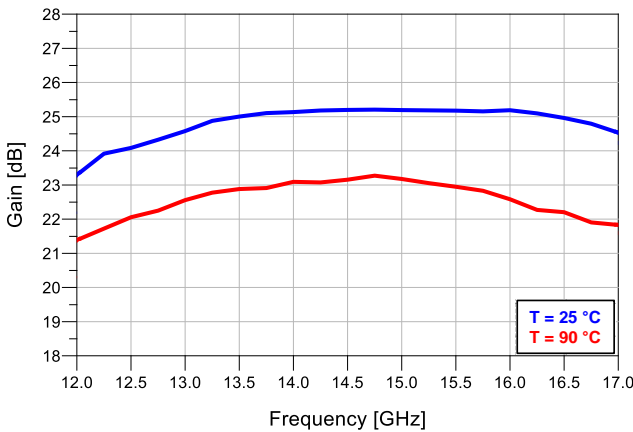

Drain Current Vs. Temperature

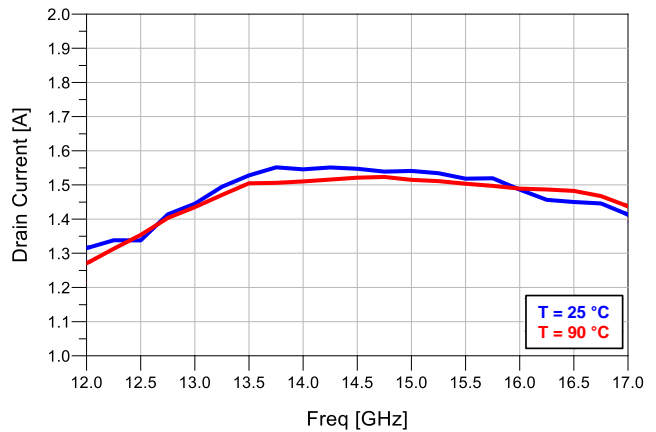

Dissipated Power Vs. Temperature

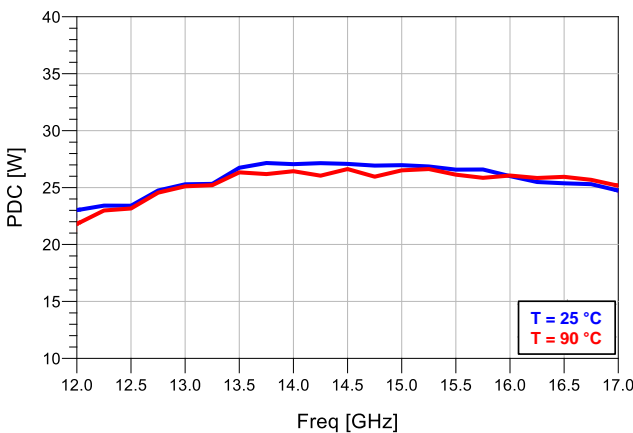

TX-to-RX Isolation Vs. Temperature

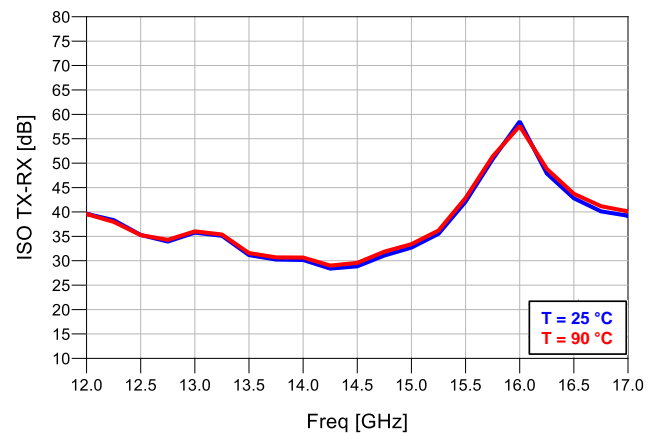

Power Performance – Transmit

Test conditions unless otherwise noted: $Tx_VD = 17.5\text{ V}$, $Tx_IDq = 0.4\text{ A}$, $VC1 = -20\text{ V}$, $VC2 = 0\text{ V}$, TX_VG pulse = (150 μs – 30%), $Rx_VD = 10\text{ V}$, $Rx_VG = -7\text{ V}$. 25 °C.

Output Power Vs. Input Power

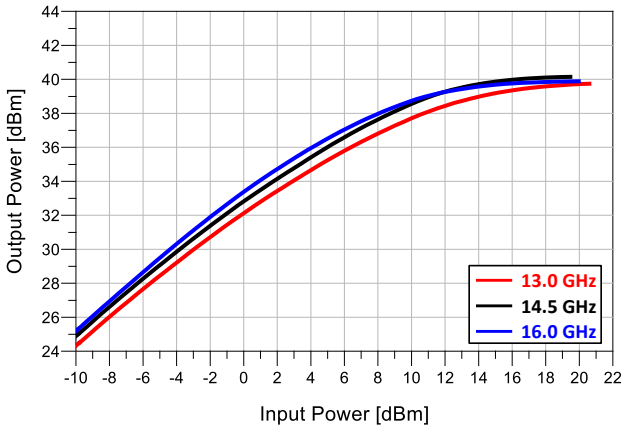

PAE Vs. Input Power

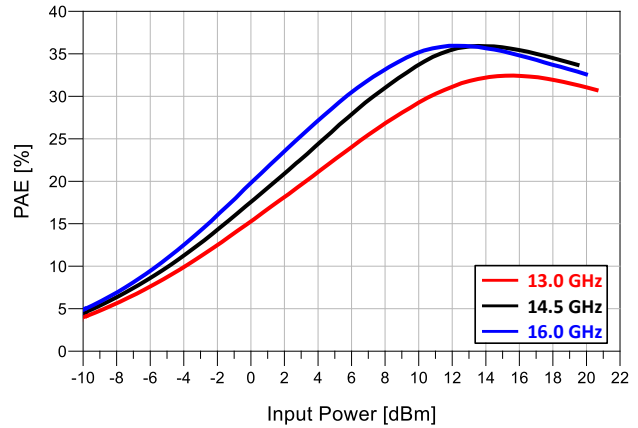

Power Gain Vs. Input Power

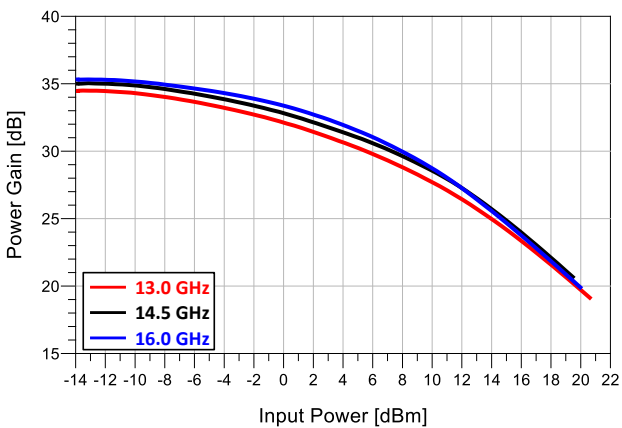

Drain Current Vs. Input Power

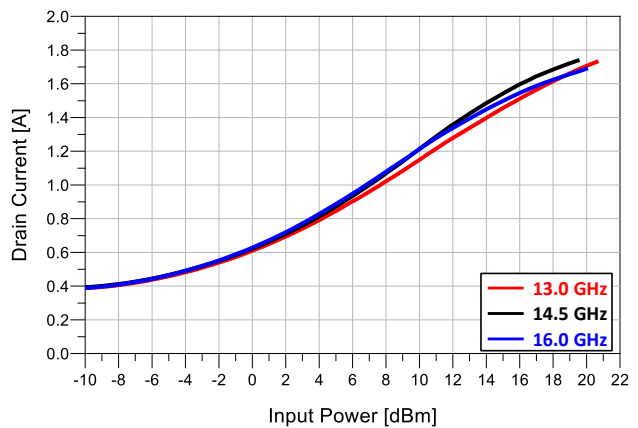

Peak Power Consumption Vs. Input Power

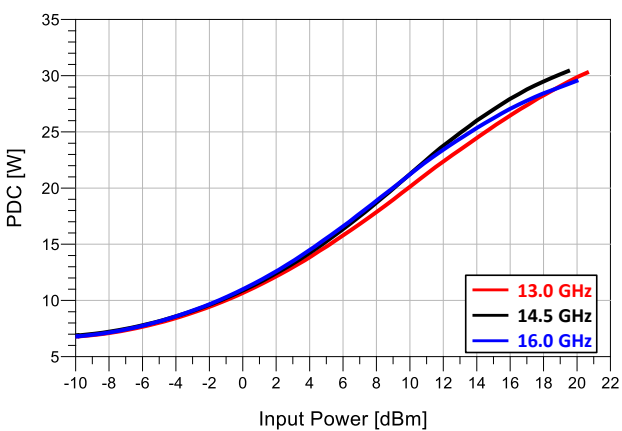

Power Leakage at RX output port Vs. TX Output Power

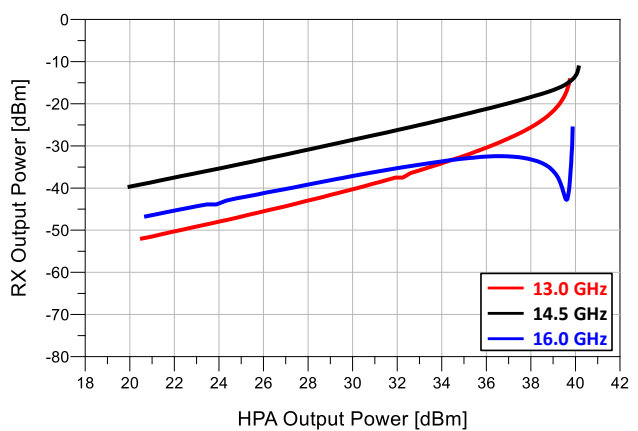

Small Signal Performance – Receive

Test conditions unless otherwise noted: $Rx_VD = 10\text{ V}$, $Rx_IDq = 35\text{ mA}$, $VC1 = 0\text{ V}$, $VC2 = -20\text{ V}$, $Tx_VD = 17.5\text{ V}$, $Tx_VG = -5\text{ V}$.

Linear Gain Vs. Temperature

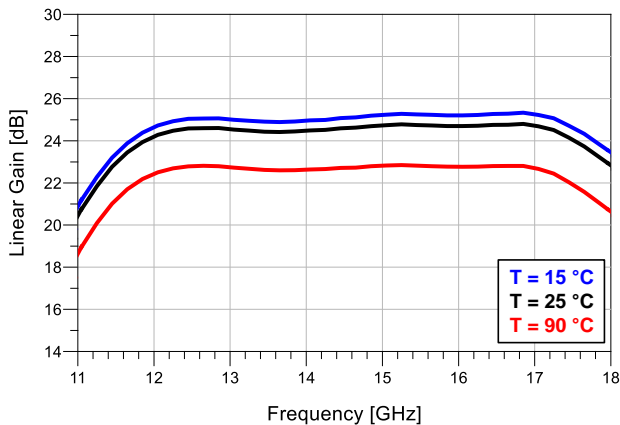

Noise Figure Vs. Temperature

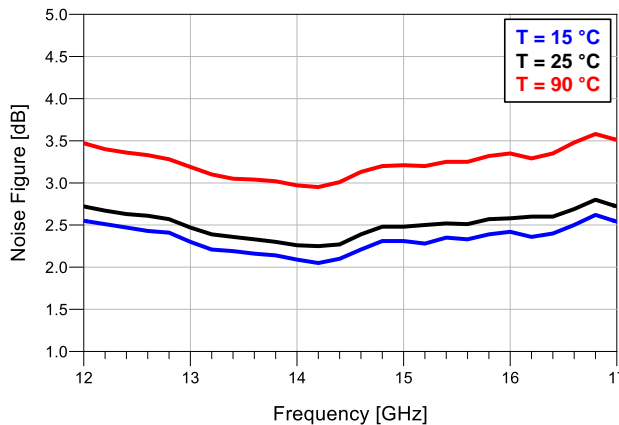

Input Return Loss Vs. Temperature

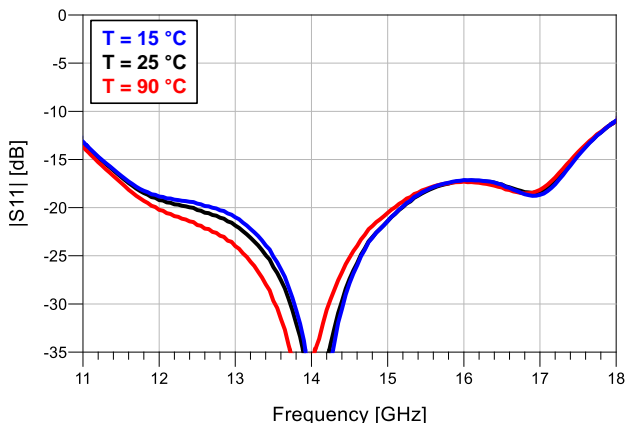

Output Return Loss Vs. Temperature

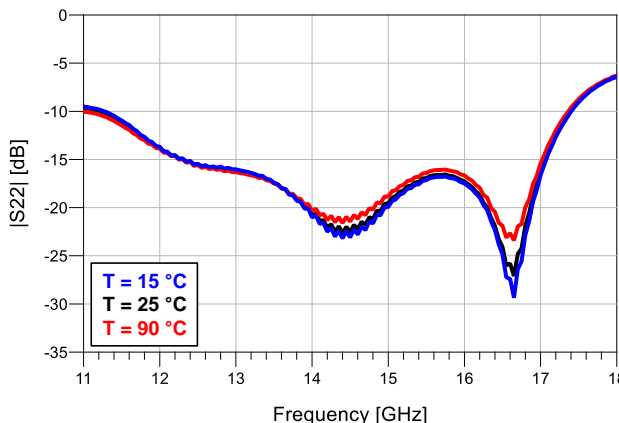

Power Performance & Linearity – Receive

Test conditions unless otherwise noted: Rx_VD = 10 V, Rx_IDq = 35 mA, VC1 = 0 V, VC2 = -20 V, Tx_VD = 17.5 V, Tx_VG = -5 V, 25 °C

Output Power Vs. Input Power @ 25 °C

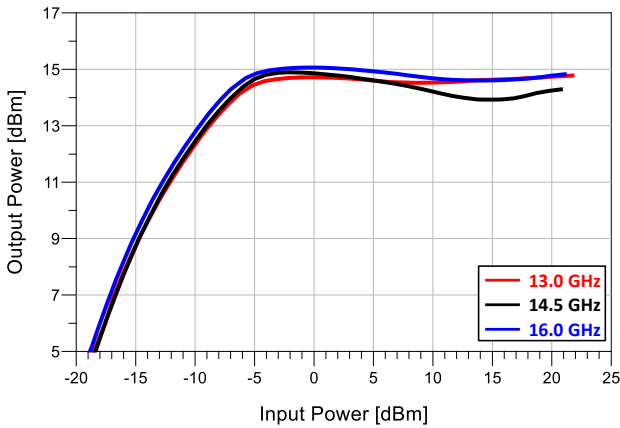

Output Power Vs. Input Power @ 13.0 GHz

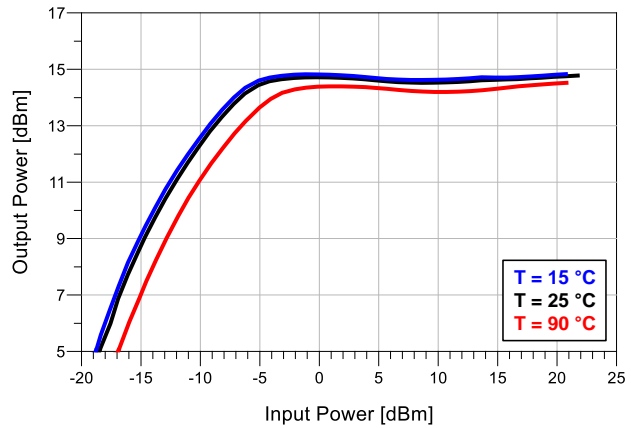

Output Power Vs. Input Power @ 9.75 GHz

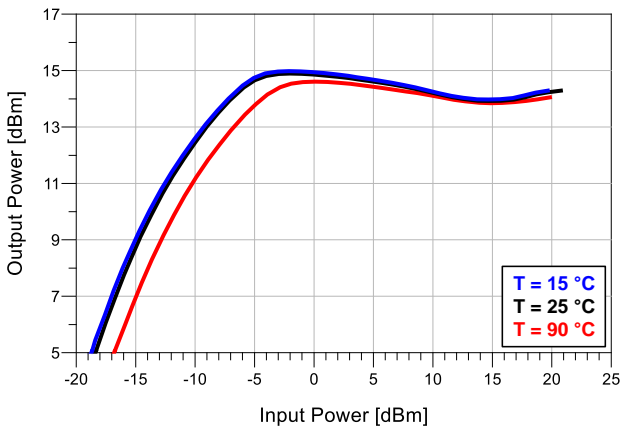

Output Power Vs. Input Power @ 11.0 GHz

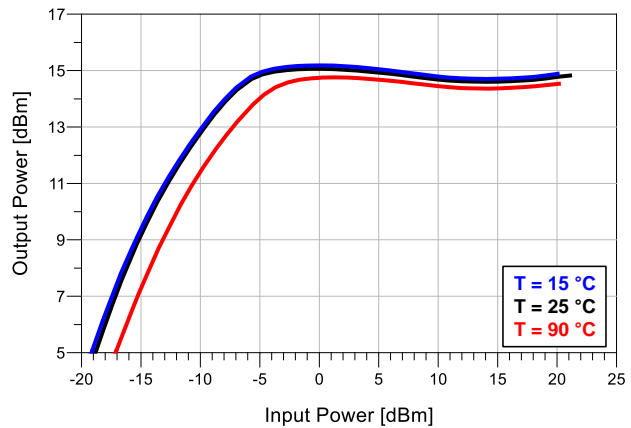

IMD3 Vs. Output Power

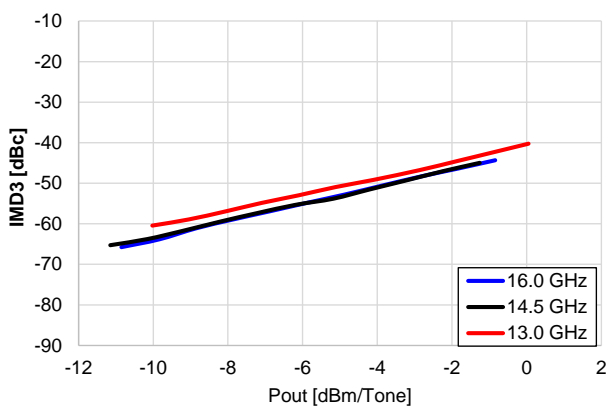

Output TOI @ -33 dBm / Tone

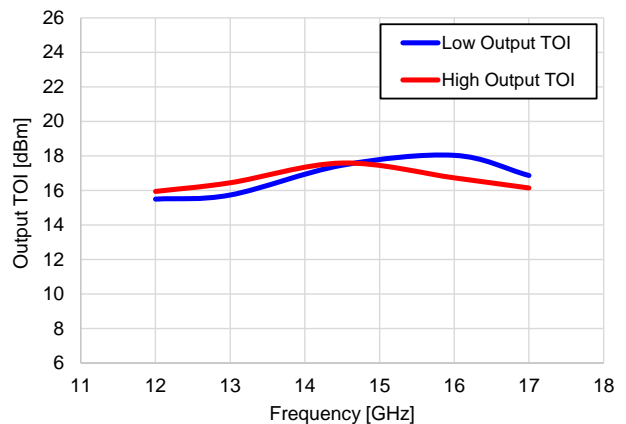

Timing Performance

Test conditions unless otherwise noted:

- Transmit: $Tx_VD = 17.5\text{ V}$, $Tx_IDq = 0.4\text{ A}$, $VC1 = -20\text{ V}$, $VC2 = 0\text{ V}$, $Rx_VD = 10\text{ V}$, $Rx_VG = -7\text{ V}$. (150 μs , 30%). 25 °C.
- Receive: $Rx_VD = 10\text{ V}$, $Rx_IDq = 35\text{ mA}$, $VC1 = 0\text{ V}$, $VC2 = -20\text{ V}$, $Tx_VD = 17.5\text{ V}$, $Tx_VG = -5\text{ V}$. 25 °C.

Rx to Tx switching time – RF signal @ Antenna

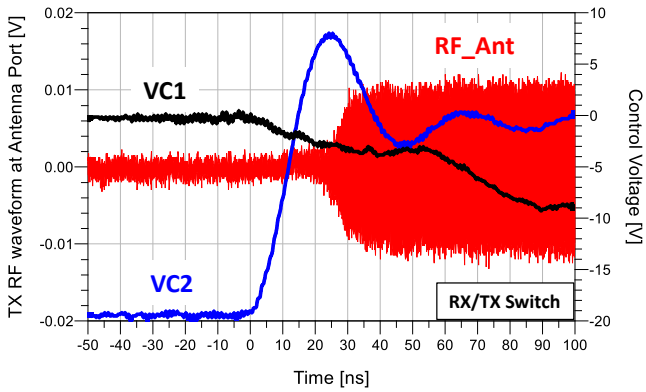

Tx to Rx switching time – RF signal @ RX port

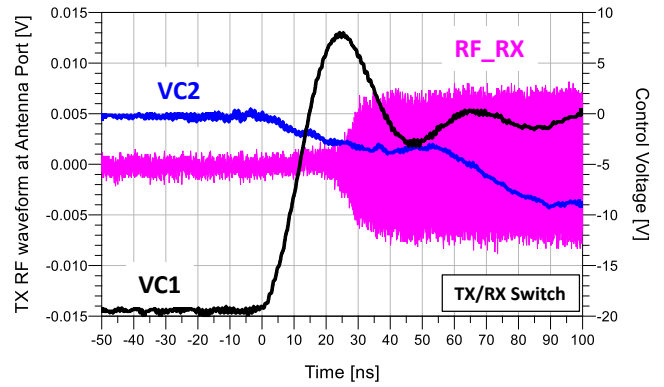

Recovery Time on Receive chain

RFin: Input Power at Antenna port; RFout: Output Power at RX port
Jamming signal: 20 dBm

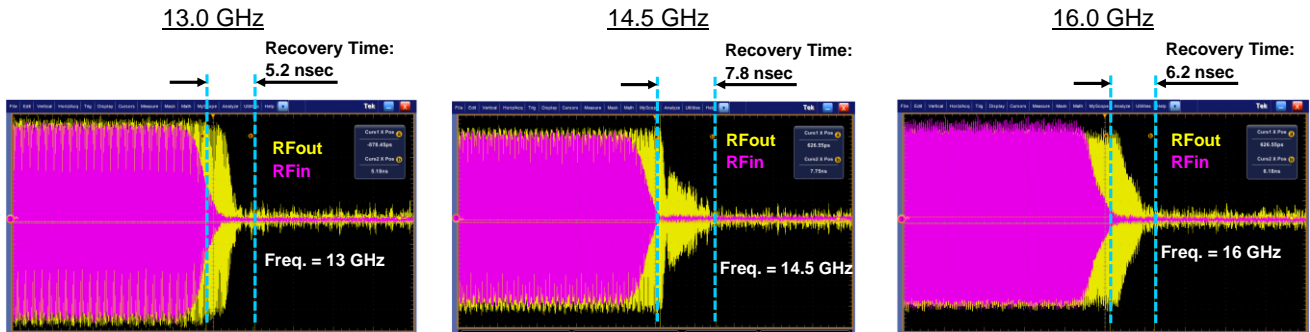

Mechanical information

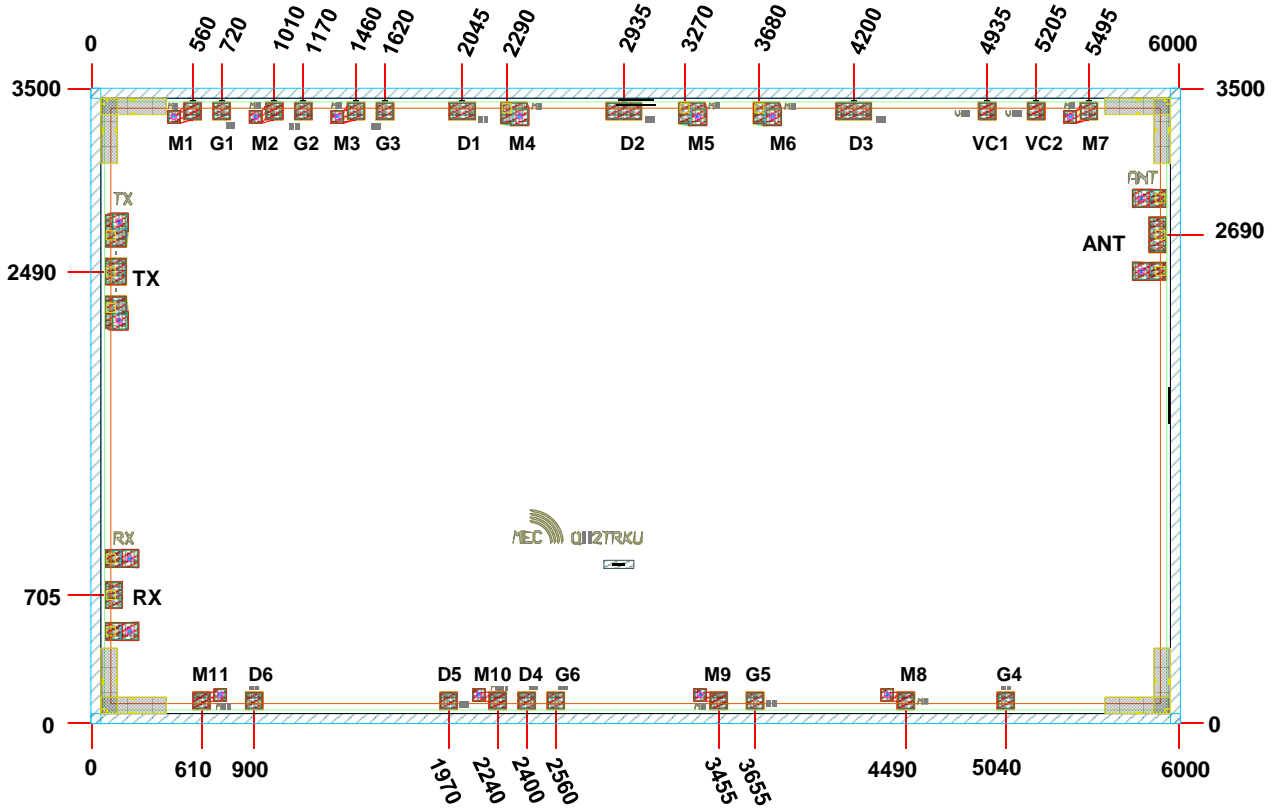

- Units: micrometres (μm)
- Chip dimensions: 6000 μm x 3500 μm ± 35 μm
- Chip Thickness is 70 μm ± 5 μm
- Chip edge to bond pad dimensions are shown to center of pad
- Ground is backside of die

Bond Pad Description

Bond Pad #	Pad Size (μm)	Description
TX	150 x 120	Input transmit RF Port
RX	150 x 100	Output receive RF Port
ANT	200 x 100	Antenna In/Out RF Port
VC1, VC2	100 x 100	Control Voltages for Tx/Rx switch
G1 ... G3	100 x 100	Gate Bias for Transmit chain. Typ. values and current at p. 2.
G4 ... G6	100 x 100	Gate Bias for Receive chain. Typ. values and current at p. 2.
D1 ... D3	200 x 100	Drain Bias for Transmit chain. Typ. values and current at p. 2.
D4 ... D6	100 x 100	Drain Bias for Receive chain. Typ. values and current at p. 2.
M1 ... M11	100 x 100	Ground pad

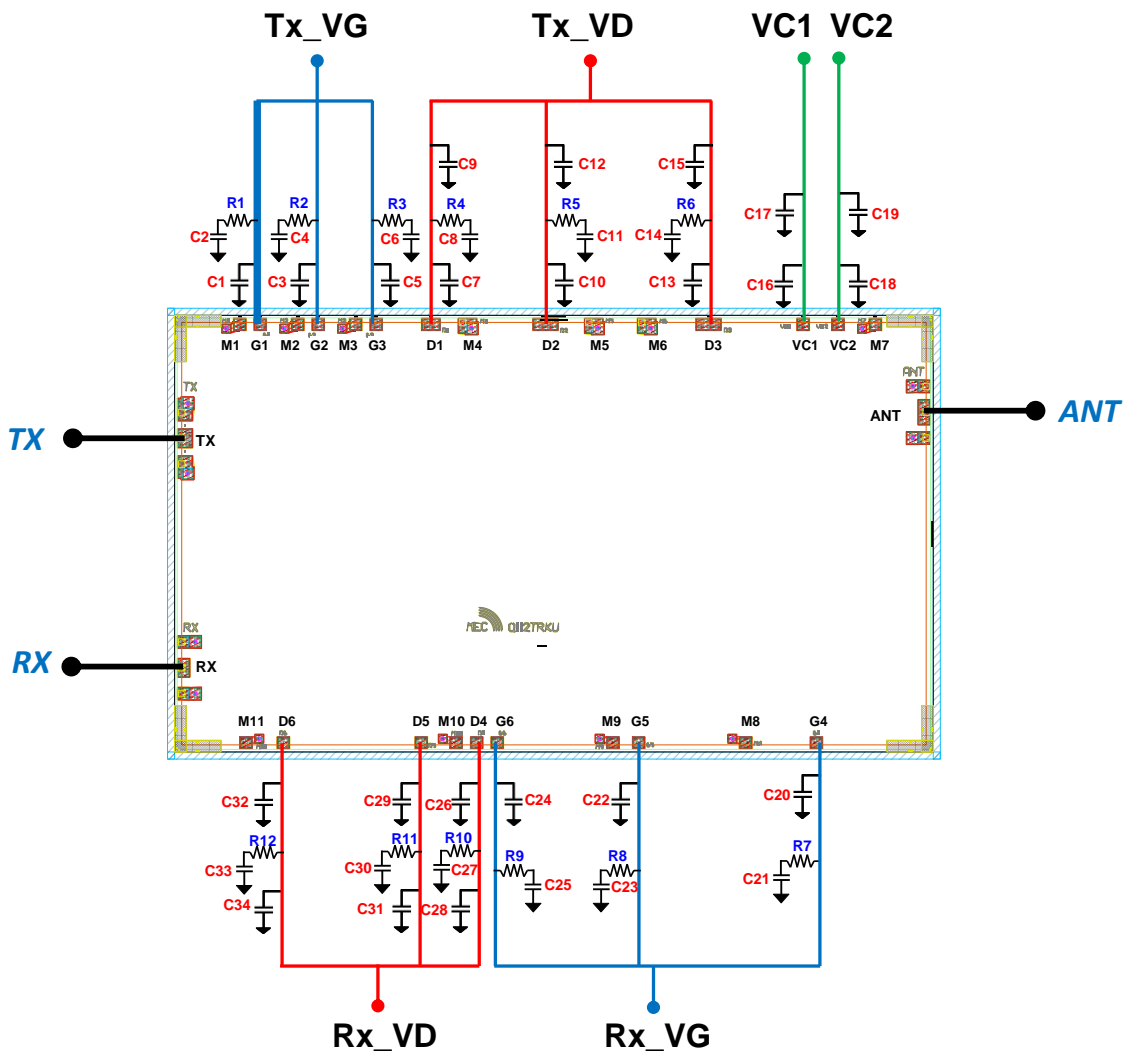

Ref.	Component	Value	Description
C1, C3, C5, C7, C10, C13, C16, C18, C20, C22, C26, C29, C32	MIM Capacitor	100 pF	Low Frequency Bypass Capacitor
C2, C4, C6, C8, C11, C14, C17, C19, C21, C23, C25, C27, C30, C33	SMT Capacitor	10 nF	Low Frequency Bypass Capacitor
C9, C12, C15, C28, C31, C324	SMT Capacitor	1 μF	Low Frequency Bypass Capacitor
R1... R12	SMT Resistor	5 Ω	Low power Resistor





Bias-up Procedure

1. Set current limits:
 - Tx_ID = 2 A; Rx_ID = 50 mA; IC1=IC2 = 5 mA;
 - Tx_IG = Rx_IG = 10 mA
2. Set Tx_VG = -5 V and Rx_VG = -7 V;
3. Set VC1 = -20 V (0 V) and VC2 = 0 V (-20 V) for Transmit (Receive);
4. Set Tx_VD = 17.5 V and Rx_VD = 10 V;
5. Adjust Tx_VG (Rx_VG) to achieve required current for Transmit (Receive) keeping Rx_VG = -7 V (Tx_VG = -5 V).
6. Apply RF signals.

Bias-down Procedure

1. Turn off RF signals.
2. Set Tx_VG = -5 V and Rx_VG = -7 V;
3. Set Tx_VD = 0 V and Rx_VD = 0 V;
4. Turn off drain supply;
5. Turn VC;
6. Turn off gate supply.

Evaluation Board and Bonding Diagram

-  MIM CAP, 100 pF, 25 V
-  CAP 0402, 1 uF, 25 V
-  CAP 0402, 10 nF, 10 V
-  RES 0402, 5 Ohm

Bonding Diagram

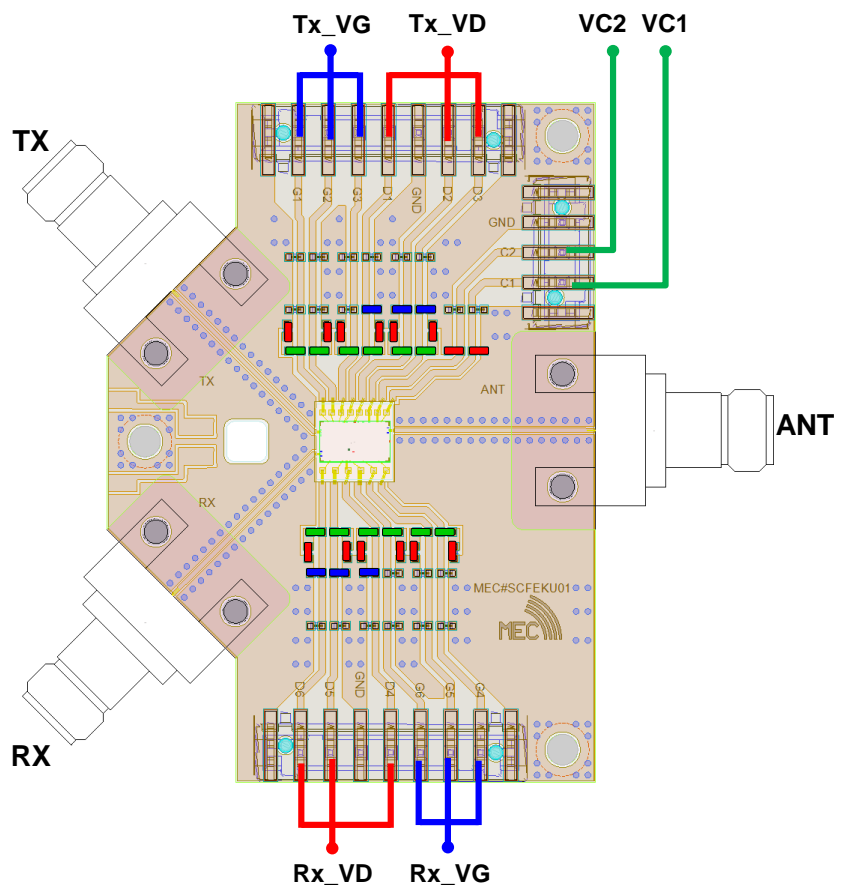
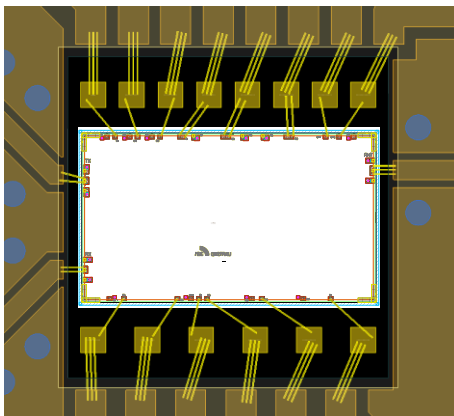

0.008" thick Rogers Corp. RO4003C ($\epsilon_r = 3.35$) with copper coin and 0.04" copper carrier. Metal layers 0.5 oz. copper cladding. Microstrip to Coplanar transition optimized to access the MMIC. Microstrip to coplanar transition for connector interface optimized for the Southwest Microwave end launch 1092-01A-6.

Assembly Guideline

The backside of the MMIC is RF ground. Die attach should be accomplished with electrically and thermally conductive epoxy only. Eutectic attach is not recommended. Follow manufacture instructions for epoxy curing.

Standard assembly procedures should be followed for high frequency devices. The top surface of the semiconductor should be made planar to the adjacent RF transmission lines. Vacuum pencils and/or vacuum collets are the preferred method of pick up. Do not make contact directly with the die surface as this will damage the monolithic circuitry. Air bridges must be avoided during placement. Handle with care.

RF connections should be made as short as possible to reduce the inductive effect of the bond wire. Use of a 25 μm thermosonic wedge bonding is highly recommended as the loop height will be minimized. Force, time, and ultrasonic are critical parameters.

RoHS Compliance

The product is compliant with the 2011/65/EU RoHS directive 2015/863/EU and REACH N° 1907/2006.

Contact Information

For additional technical Information and Requirements: contact.mec@mec-mmic.com

Notice

The furnished information is believed to be reliable. However, performances and specifications contained herein are based on preliminary characterizations and then susceptible to possible variations. On the basis of customer requirements, the product can be tested and characterized in specific operating conditions and, if needed, tuned to meet custom specifications.

The contents of this document are under the copyright of MEC srl. It is released by MEC srl on condition that it shall not be copied in whole, in part or otherwise reproduced (whether by photographic, reprographic, or any other method) and the contents thereof shall not be divulged to any person other than inside the company at which has been provided by MEC.